

**Installation, Operating and Maintenance
Instructions for**

Jola Floating Switches
SI/.../Variant . Ex I M2,
SI/.../Variant . Ex II 1 G or . Ex II 2 G
and
Jola Immersion Probes with mounted Floating Switches
TS/.../. x SI/.../Variant . Ex I M2 or
TS/.../. x SI/.../Variant . Ex II 2 G

Ex ia I Mb
Ex ia IIC T1...T6 Ga or
Ex ia IIB T1...T6 Ga or
Ex ia IIC T1...T6 Gb or
Ex ia IIB T1...T6 Gb or
Ex ia IIA T1...T6 Gb





**These Installation, Operating and Maintenance
Instructions must always be handed over to the
fitter/operator/service personnel
of our products together with all other user
documentation and information!**

**They should be stored in a safe place together
with all other user documentation and information
so they can be consulted again when necessary at
any time!**

Jola Spezialschalter GmbH & Co. KG
Klostergartenstr. 11 • 67466 Lambrecht (Germany)
Tel. +49 6325 188-01 • Fax +49 6325 6396
contact@jola-info.de • www.jola-info.de



1. Area of application

The floating switches or the immersion probes with mounted floating switches



<p style="text-align: center;">JOLA D-67466 Lambrecht</p> <p style="text-align: center;">CE 0080</p> <p style="text-align: center;">SI/.../Variant .  I M2 or SI/.../Variant .  II 1 G or II 2 G or TS/.../. x SI/.../Variant .  I M2 or TS/.../. x SI/.../Variant .  II 2 G</p> <p style="text-align: center;">(serial number) (production year)</p> <p style="text-align: center;">Ex ia I Mb Ex ia IIC T1...T6 Ga or Ex ia IIB T1...T6 Ga or Ex ia IIC T1...T6 Gb or Ex ia IIB T1...T6 Gb or Ex ia IIA T1...T6 Gb</p> <p style="text-align: center;">Tamb : - 20°C or - 15°C or 0°C or + 8°C to + 60°C (see name plate)</p> <p style="text-align: center;">INERIS 03ATEX0149</p>

are binary contact devices for use

- ◆ **in underground areas in mines as well as in above-ground areas of mines which could be at risk due to firedamp and/or flammable dusts:**

SI/.../Variant .  I M2,
TS/.../. x SI/.../Variant .  I M2

- ◆ **in above-ground areas which could be at risk due to a potentially explosive atmosphere:**

SI/.../Variant .  II 1 G: in zone 0, 1 or 2,
SI/.../Variant .  II 2 G: in zone 1 or 2,
TS/.../. x SI/.../Variant .  II 2 G: in zone 1 or 2

The floating switches SI/... or the immersion probes TS/.../1 x SI/.../Variant . with one mounted floating switch SI/.../Variant . serve as **individual switches** that give off an alarm signal when the liquid level reaches a certain point (e.g. high-

level alarm or low-level alarm).

The **combination of 2 switches SI/.../Variant . or the immersion probe TS/.../2 x SI/.../Variant . with 2 mounted floating switches** serves to control a pump, for example (ON-OFF via a suitable downstream external pump controller) or a solenoid valve (OPEN-CLOSE via a suitable downstream external solenoid valve controller).

The use of more than 2 SI/..., Variant . floating switches or an immersion probe TS/.../. x SI/.../Variant . with more than 2 mounted floating switches SI/.../Variant . allows you to perform more complex switching tasks (e.g. overflow protection, high-level alarm, pump ON, pump OFF, low-level alarm, run-dry protection etc.).

Depending on type, the floating switches are designed **for mounting from the side and/or from above**. The mounting orientation is described in the supplied product documentation.

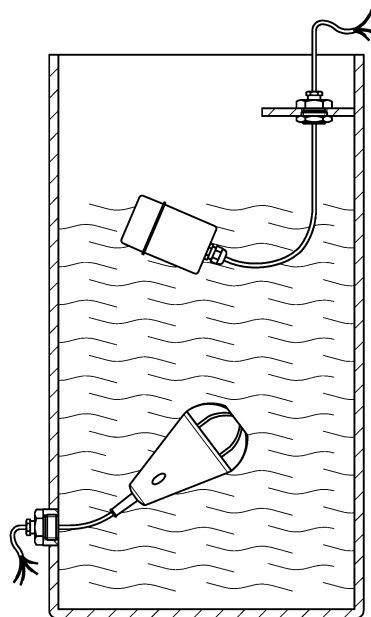

To ensure correct operation, the floating switches must be fixed (generally by their cables). The fixing mode depends on the switch type and is also described in the supplied product documentation.

The units are not suitable for use in turbulent liquids (e.g. in stirrer tanks).

If there is a risk of any kind that **adhesive residues or solid particles** might impair the function of the floating switches, then they are not suitable for the application in question.

All the technical parameters of the floating switch or immersion probe are listed in this brochure and the accompanying product description. You must always observe and follow all the instructions relating to these parameters. The units may not be used for applications outside the specified parameter range.

If the product description is not supplied with the product or is lost, you must always request a copy of the description prior to installation, connection or start-up and ensure that it is read and observed by the suitably qualified specialist personnel. Otherwise the floating switches may not be installed, connected and started up.

2. Preconditions for safe use

- ◆ **Maximum values for floating switches SI/.../Variant . equipped with a connecting cable and immersion probes TS/.../. x SI/.../Variant .**

Sensor type	Type designation	Li	Ci
Floating switches	SI/.../Variant .	1 μ H per meter connecting cable	200 pF per meter connecting cable
Immersion probes	TS/.../. x SI/.../Variant .	36 μ H	7.2 nF

- ◆ **Special requirements/conditions for the safe use of the floating switch SI/..., Variant . and the immersion probe TS/.../. x SI/.../Variant .**

To ensure safe operation, power supply to the floating switch SI/.../Variant . or to each floating switch SI/.../Variant . of an immersion probe TS/.../. x SI/.../Variant . must be via a Ex ia voltage source with output circuits which are approved as Ex ia intrinsically safe for use in the potentially explosive atmosphere which corresponds to the gas explosion group in which the device is installed: IIC, IIB, IIA respectively I.

More than one floating switch SI/.../Variant . or more than one floating switch of an immersion probe TS/.../. x SI/.../Variant . can be connected to the same voltage source.

Always observe all the restrictions specified with regard to the voltage source.

The output parameters of the voltage source must be equivalent to or lower than the input parameters of the units as defined below.

Maximum input parameters at the wires or connection terminals:

Variant	Temperature class	Ui (V) max.	Ii (A) max.
Variant 0	T6	42	0.1
Variant 1	T6	42	0.1
Variant 2	T1	42	0.1
Variant 2	T2	40	0.1
Variant 2	T3	30	0.1
Variant 2	T4	22	0.1
Variant 2	T5	16	0.1
Variant 2	T6	13	0.1

3. Additional conditions for safe operation

Before using the floating switch SI/.../Variant ., you must ensure that the materials used in the float element, the gaskets and the cable of the floating switch are sufficiently chemically and mechanically resistant to the liquid to be monitored and all external influences.

In case of doubt, consult a suitably trained expert prior to use. Do not use the product before these questions have been fully clarified.

Before using the immersion probe TS/.../. x SI/.../Variant ., you must ensure that the materials used in the immersion tube, the screw-in nipple or mounting flange, the float element, the gaskets and the cable of the floating switch SI/..., Variant . are sufficiently chemically and mechanically resistant to the liquid to be monitored and all external influences. You must also ensure that the terminal box is sufficiently chemically and mechanically resistant to all external influences.

In case of doubt, consult a suitably trained expert prior to use. Do not use the product before these questions have been fully clarified.

4. Installation, connection, start-up and maintenance, general regulations

Installation, connection, start-up and maintenance of the floating switches or immersion probes may only be performed by suitably qualified specialist personnel in line with all the information material and documentation supplied with the floating switches or immersion probes and following all instructions contained therein.

The qualified specialist personnel must ensure that they are familiar with all valid standards, regulations, local requirements and specific conditions, in particular

the standards, regulations, local requirements and specific conditions relating to explosion protection – and must proceed accordingly.

The entire installation set-up of the floating switches

SI/.../Variant . Ex I M2 or Ex II 1 G or Ex II 2 G,

the accessories and

the immersion probes TS/.../. x SI/.../Variant . Ex I M2 or Ex II 2 G

must always comply with the standard EN 60 079-14 resp. the replacing standard.

You must always read – and adhere to the instructions outlined in - the yellow DIN A 5 leaflet "User information/Instructions for use with mounting, operating and maintenance instructions for the product...". If the leaflet is not supplied with the product or is lost, you must always request a replacement leaflet from Jola.

5. Installation of the floating switches SI/.../Variant .

Depending on the type, the floating switches SI/.../Variant . may be **mounted in different ways**. **The possible mounting modes** for the various floating switch types are outlined in the **supplied product description**.

To ensure correct switching, the cable of the floating switch must be fixed at the desired working height (using a stuffing gland, for example, with many floating switch types mounted from the side, and using a fixing weight, for example, with switches mounted from above).

You must also ensure that the floating switches are **always** able to move freely.

The following guidelines apply for the various mounting and installation modes:

◆ **Mounting using a stuffing gland:**

A stuffing gland can be used both

for mounting a floating switch SI/.../Variant . **without internal fixing weight or without external fixing weight (in special cases also for switches with internal fixing weight or with external fixing weight) **from the side** through a tank wall**

and

for mounting a floating switch SI/.../Variant . **with internal fixing weight or with external fixing weight **from above** through a tank wall or on a crossbeam.**

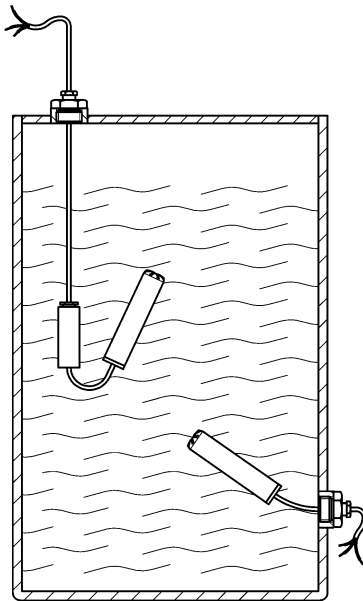

To mount a floating switch from the side using a stuffing gland, a sleeve of corresponding size must be present in the tank at the working height. You should position the sleeve in line with the diagram "Switching action in liquids with a specific gravity of 1g/cm^3 " in the supplied product documentation.

To mount a floating switch from above using a stuffing gland, a sleeve of corresponding size must be present. In pressureless tanks or on crossbeams, however, a smooth borehole of a suitable size may be adequate in place of the sleeve. In this case, the stuffing gland is fastened in place from below using a counter nut.

To fasten the cable of the floating switch in the stuffing gland, first unscrew and remove the pressure screw, remove the gasket as well as the metal ring, and then insert the cable of the floating switch into the stuffing gland **from the side facing the inside of the tank**. This is the side with the conical outlet for the cable. Then pull the gasket and then the metal ring (in that order) onto the cable. Push the cable through the opening of the pressure screw, then tighten the pressure screw using a suitable open end spanner.

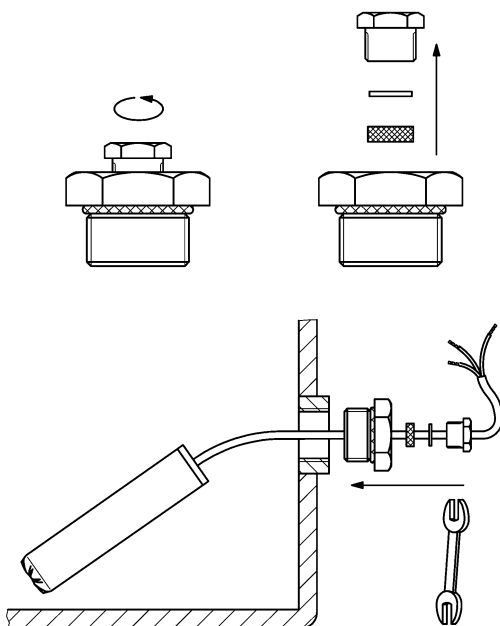

The **pressure screw should be tightened firmly but not so firmly** that it damages the gasket and the cable.

When mounting the switch, check whether the existing stuffing gland possesses a **gasket** with an internal diameter that is suitable for the cable of the floating switch. In other words, check whether the gasket **would adequately seal off the cable** after the pressure screw is tightened.

If this is not the case, you must purchase suitable gaskets (e.g. from Jola) which match the cable used.

If you simultaneously order floating switches and stuffing glands from Jola – or if you order the stuffing glands at a later date but specify the cable used for the floating switch – we will normally deliver the correct gasket that matches the cable.

Always ensure that both the **stuffing gland** and the **gaskets** are **sufficiently chemically and thermally resistant to the liquid to be monitored**.

The **gaskets supplied by Jola are standard gaskets** which may not be suitable for all liquids. If you have the slightest doubt, you must replace them with other more suitable gaskets.

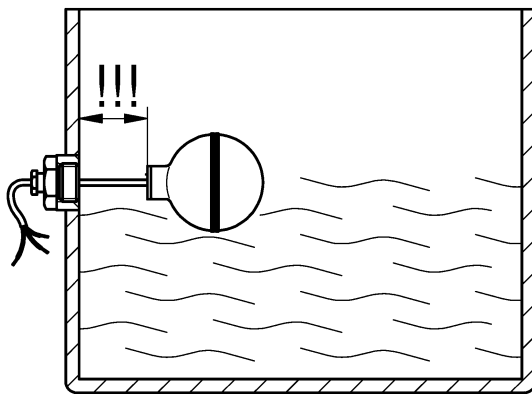

It is essential to ensure that the cable between the fastening point of the stuffing gland and the floating switch possesses at least the minimum length specified in the product documentation. If the cable does not possess at least the minimum specified length, this can lead to premature breaking of the wires and may also impair the

If the **tank is accessible from the inside**, the size of the stuffing gland is not important.

If, however, the **tank is only accessible from the outside**, the stuffing gland selected must be of sufficient size to allow insertion of the floating switch through the corresponding sleeve opening before the stuffing gland is screwed in place (the SI/SSP.... fits through a G1 sleeve opening, for example).

If you want to mount a large floating switch in a tank that is not accessible from the inside, you must use a flange of suitable dimensions for mounting from the outside.

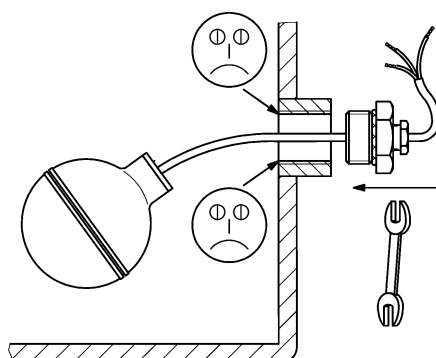

When mounting the floating switches, take care to ensure that the switch and in particular the cable are not **damaged by sharp edges and objects**.

◆ **Mounting using a metallic mounting pipe:**

Depending on the application, you can also fasten the floating switch(es) at the desired switching height(s) using a metallic mounting pipe.

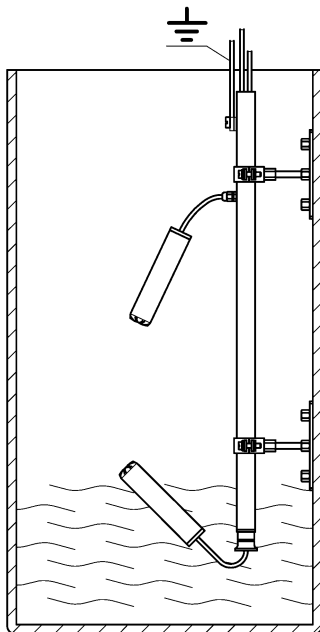

The metallic mounting pipe has to be included to the potential equalisation concept of the whole installation.

You must always consult the local supervisory authorities concerning the design and the integration of the mounting pipe in the potential equalisation concept for the system.

When mounting the floating switches, take care to ensure that the switch and in particular the cable are not damaged by sharp edges and objects.

◆ **Mounting using an internal fixing weight or an external fixing weight:**

The working height of the floating switch can be determined within an approximate range via an internal fixing weight or an external fixing weight. Simply lower the floating switch on its cable to the desired working height. When it has reached the desired height, you can then fasten the cable in place – using a stuffing gland, for example.

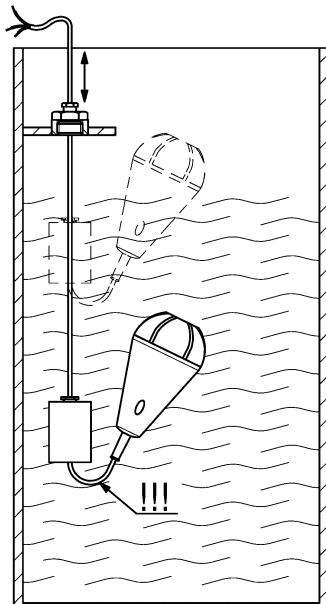

Here an example of the installation of a floating switch **SI/SSX/LF/4/1/K/PURLF/Variante** with antistatic cable (with external conductive sheath) using the metallic fixing weight without potential equalisation terminal of the type **FG 55x93/Ex/KLF** or **FG 55x93/E/KLF/Ex**.

The external fixing weight is fastened to the cable in different ways depending on the type of fixing weight. The supplied product documentation outlines the mounting details.

In all cases, however, the fixing weight has to be mounted so that the pressure screw (in case of the fixing weight FG 55x93/Ex/KLF or FG 55x93/E/KLF/Ex: the 2 screws) point(s) upwards following mounting and the part without screw(s) points downwards = in direction of the floating switch.

Each fixing weight has to be correctly fixed using the pressure screw (in case of the fixing weight FG 55x93/Ex/KLF or FG 55x93/E/KLF/Ex: using the 2 screws) **so that it cannot move anymore on the cable**.

You must ensure that the cable has at least the minimum length between the bottom edge of the external fixing weight and the floating switch specified in the product documentation, plus additionally 100 mm.

A longer cable is highly beneficial to the proper functioning and mechanical durability of the floating switch.

If the cable does not possess the minimum length as specified above, this can lead to premature breaking of the wires and may also impair the functioning of the floating switch.

When mounting the floating switch, take care to ensure that the switch and in particular the cable are not damaged by sharp edges and objects.

6. Installation of the immersion probes TS/.../. x SI/.../Variant .:

◆ Immersion probes without screw-in nipple or flange

If you have ordered and received immersion probes TS/.../. x SI/.../Variant . without threaded screw-in nipple or flange, they must be fastened on the shaft wall or on a crossbeam using conventional fastening materials such as stainless steel clamps or other stainless steel screw fasteners that suit the mounting environment.

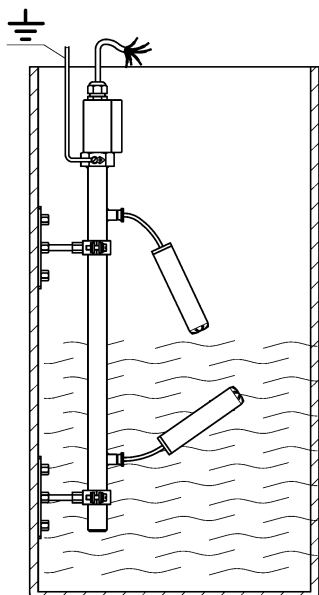

The immersion probe has to be included in the potential equalisation concept of the whole installation.

When mounting the immersion probe, take care to ensure that the floating switches and in particular their cables are not damaged by sharp edges and objects.

You must also ensure that the floating switch(es) mounted on the immersion probe is (are) always able to move freely.

◆ Immersion probes with threaded screw-in nipple or flange

If you have ordered and received immersion probes TS/.../. x SI/.../Variant .. with threaded screw-in nipple or flange, these probes are installed via the relevant opening. Depending on the application, it may be necessary to seal off the threaded screw-in nipple or flange using a suitable gasket.

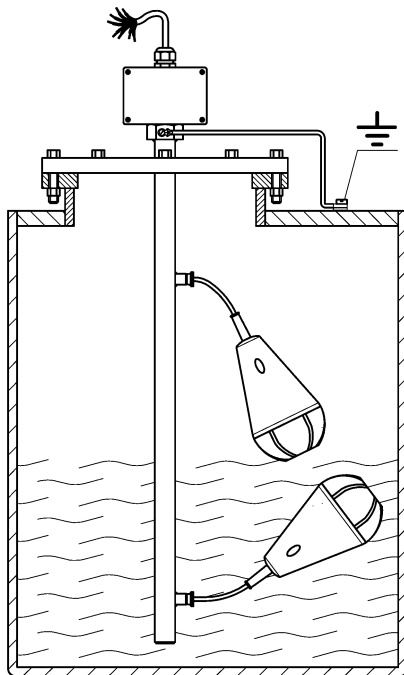

The immersion probe has to be included to the potential equalisation concept of the whole installation.

When mounting the immersion probe, take care to ensure that the floating switches and in particular the cable are not damaged by sharp edges and objects.

You must also ensure that the floating switch(es) mounted on the immersion probe is (are) always able to move freely.

7. Wiring and connection to the potential equalisation system

Wire the **contact of the individual floating switch SI/.../Variant .** as shown in the circuit diagram in the supplied product documentation. **If intrinsically safe contact protection relays are used, connect the floating switches in line with the instructions contained in the corresponding production description.**

Wire the **contacts of the immersion probes TS/.../. x SI/.../Variant .** as shown in the supplied circuit diagram. **If intrinsically safe contact protection relays are used, connect the contacts in line with the instructions contained in the corresponding production description.**

Potential equalisation is necessary with:

- the floating switches SI/SSR 1/K/.../Variant .,
- the floating switches made of antistatic electrically conductive plastic,
- the metal accessories (e.g. metal stuffing glands, metal fixing weights etc.),
- the accessories made of antistatic electrically conductive plastic (e.g. stuffing glands, fixing weights etc.) and
- the immersion probes TS/.../. x SI/.../Variant . .

Floating switches SI/SSR 1/K/.../Variant ..:

Connect the green-yellow conductor of the cable of the floating switch **and**, if present, the metallic screen of the cable of the floating switch to the potential equalisation system.

Floating switches SI/... made of antistatic electrically conductive plastic:

-Fitted with a normal, non-antistatic cable:

Connect the green-yellow conductor of the cable of the floating switch **and**, if present, the metallic screen of the cable of the floating switch to the potential equalisation system.

-Fitted with an antistatic electrically conductive cable:

The 3 metallic conductors which are twisted together to one conductor without insulation have to be connected to the potential equalisation system.

Metal accessories (e.g. metal stuffing glands, metal fixing weights etc.):

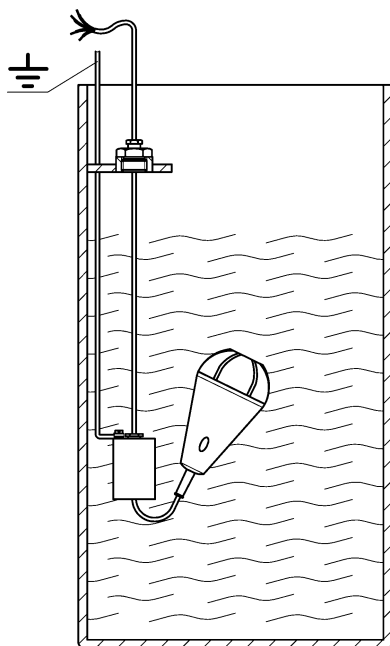

Connect the potential equalisation terminal on the accessory in question to the potential equalisation system.

Accessories made of antistatic electrically conductive plastic (e.g. stuffing glands, fixing weights etc.):

Connect the potential equalisation terminal on the accessory in question to the potential equalisation system.

Special feature of the fixing weight for mounting on to antistatic cable, type FG 55x93/Ex/KLF or FG 55x93/E/KLF/Ex:

When using a floating switch **SI/SSX/LF/4/1/K/PURLF/Variant**, which is equipped with an antistatic cable (with external conductive sheath) and a fixing weight for mounting on to antistatic cable, type **FG 55x93/Ex/KLF or FG 55x93/E/KLF/Ex**, the antistatic cable (with external conductive sheath) is sufficient to serve for correct potential equalisation.

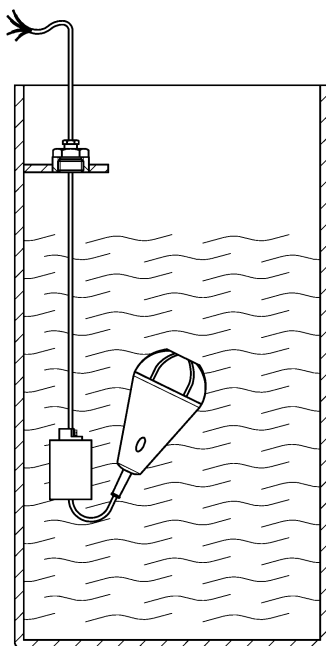

Only the fixing weight for antistatic cable, type FG 55x93/Ex/KLF or FG 55x93/E/KLF/Ex can be used for a

SI/SSX/LF/4/1/K/PURLF/Variant, floating switch (which is equipped with an antistatic cable with external conductive sheath)

without supplementary connection to the potential equalisation system.

The fixing weight must be correctly fixed to the cable using the fixing piece and the two screws.

The fixing weight has to be in totally immobilized condition on the cable following mounting.

When other metallic fixing weights or fixing weights made of antistatic electrically conductive plastic shall be used, they have to be connected to the potential equalisation system by means of the potential equalisation terminal of the fixing weight.

Immersion probes TS/.../. x SI/.../Variant .:

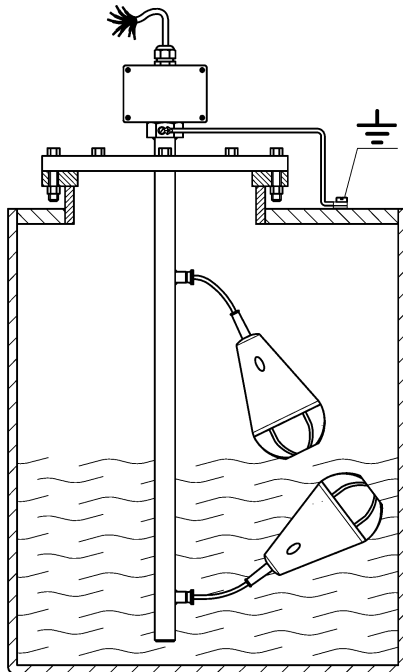

Connect the external earth connection terminal on the screw-in nipple or on the flange of the unit to the potential equalisation system.

Connection to the potential equalisation system is essential for safe operation and must never be neglected.

You must also always ensure that you are connecting to the potential equalisation system and not to a potential earth.

The entire installation set-up must always comply with the standard EN 60 079-14 resp. the replacing standard.

Terminal box of the immersion probes TS/.../. x SI/.../Variant .:

In the case of the immersion probes TS/.../. x SI/.../Variant ., it is important to ensure that the **cable suits the gasket insert of the cable entry of the terminal box and permits correct sealing, as a non-matching cable will negatively affect the IP protection.**

After inserting the cable, fasten the movable part of the cable entry (but do not use unnecessary force) in order to achieve the required IP protection level.

Connect the cable itself as shown below:

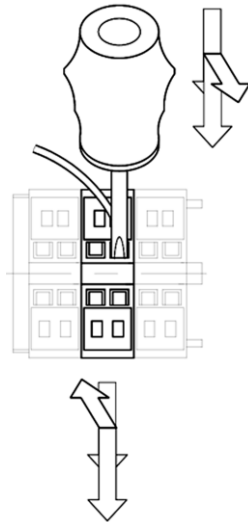

Push a screwdriver into the opening as shown in the drawing. Open the relevant terminal by pushing the screwdriver down towards the centre of the terminal block using a lever action.

8. Start-up

Prior to start-up, you must re-check the mounting position, the mechanical fastening and the electrical connection.

In particular, you must check once again that the unit/units is (are) also connected to the corresponding, admissible intrinsically safe circuit(s).

In addition, you must also check and verify that there is no possibility whatsoever of hazardous conditions occurring due to non-adherence to any of the relevant instructions, standards or official regulations.

In the case of **floating switches SI/.../Variant .**, make sure that you seal the connection enclosure (e.g. switch cabinet) correctly after performing the relevant checks.

After performing the corresponding checks on the **immersion probes TS/.../. x SI/.../Variant .**, close the cover of the terminal box and tighten the 4 cover screws evenly and firmly but without applying unnecessary force.

Only then may the unit in question be started up electrically.

9. Maintenance

The floating switches SI/.../Variant . and the immersion probes TS/.../. x SI/.../Variant . are maintenance-free when used in low-viscosity, non-adhesive liquids that are free of solids and do not attack the component materials.

To rule out any risks, however, the floating switch or the immersion probe must be sight-checked and function-tested by qualified specialist personnel at least once a year.

Where risks cannot be ruled out, you should adhere to an inspection frequency suited to the application in question and laid down in consultation with the relevant supervisory authorities.

If the floating switch or the immersion probe is installed as a safety element within a system, it must always be inspected and checked at intervals to be agreed with the local supervisory authorities.

Prior to all maintenance work, the qualified specialist personnel must inform themselves of all valid standards, regulations, local guidelines and special conditions, in particular standards, regulations, local guidelines and special conditions concerning explosion protection and proceed accordingly.

10. Repair





All alterations and repairs to the floating switches or immersion probes must be performed by the manufacturer's suitably qualified specialist personnel. Under no circumstances may other individuals or companies perform unauthorised alterations or repairs.



EU Declaration of Conformity

Jola Speziialschalter GmbH & Co. KG
Klostergartenstr. 11
67466 Lambrecht (Germany)

declares as manufacturer under its sole responsibility that the following products, which are new and designed for use in potentially explosive atmospheres:

floating switches
SI/.../Variant .  I M2,
SI/.../Variant .  II 1 G or  II 2 G
and
immersion probes with mounted floating switches
TS/.../. x SI/.../Variant .  I M2 or
TS/.../. x SI/.../Variant .  II 2 G

Ex ia I Mb
Ex ia IIC T1...T6 Ga or
Ex ia IIB T1...T6 Ga or
Ex ia IIC T1...T6 Gb or
Ex ia IIB T1...T6 Gb or
Ex ia IIA T1...T6 Gb

comply with:

the directive 2014/34/EU (ATEX directive),
the directive 2014/30/EU (EMC directive) and
the directive 2011/65/EU (RoHS directive)

and the standards:

EN 60079-0:2009,

EN 60079-11:2012,

EN 60079-26:2007 and

DIN EN 60730-1 (VDE 0631-1):2012-10, EN 60730-1:2011

Sections 23, H.23, Annex ZD

DIN EN 61000-6-3 (VDE 0839-6-3):2011-09, EN 61000-6-3:2007+A1:2011,

DIN EN 61000-6-2 (VDE 0839-6-2):2006-03, EN 61000-6-2:2005

and

the design types (according to annex III of directive 94/9/EC or 2014/34/EU) of EC type examination certificate 03ATEX0149 and its addendums 1, 2, 3 and 4 issued by INERIS, rue J. Taffanel, 60550 Verneuil-en-Halatte (France), notified body with the number 0080.

The standard EN 60079-0:2009 is not harmonised any more. Neither the changes of the type classified as "extension" nor the changes of the type classified as "major technical changes" of the standard EN 60079-0:2012, of the standard EN 60079-0:2012+A11:2013 and the new harmonized standard EN IEC 60079-0:2018 have, however, an impact on the conformity of the equipment.

The standard EN 60079-26:2007 is not harmonised any more. Neither the changes of the type classified as "extension" nor the changes of the type classified as "major technical changes" of the new harmonised standard EN 60079-26:2015 have, however, an impact on the conformity of the equipment.

The production facility in Lambrecht has got the quality assurance notification n° 03ATEXQ405 for the production according to annex IV and VII of directive 94/9/EC or 2014/43/EU. The approval was issued by INERIS, rue J. Taffanel, 60550 Verneuil-en-Halatte (France), notified body with the number 0080.

Lambrecht, 19 May 2022



Volker Mattil, Product manager